



# The business of distributed solar power: a comparative case study of centralized charging stations and solar microgrids

Anthony L. D'Agostino,<sup>1</sup> Peter D. Lund<sup>2</sup> and Johannes Urpelainen<sup>3\*</sup>

How can distributed solar power best meet the energy needs of nonelectrified rural communities? In collaboration with a local technology provider, we conduct a techno-economic comparison of three different models of distributed solar power in rural India. We compare a centralized charging station with two solar microgrids, one based on prepaid electricity purchases and the other on a fixed monthly fee. Customers report higher levels of satisfaction and fewer technical problems with the microgrids, but the capital cost of the microgrids is much higher than that of the centralized charging station. The prepaid system exhibits poor economic performance because the customers spend very little money on electricity. These results suggest that new business models and technological innovations are needed to strike the right balance between customer needs and commercial viability. © 2016 John Wiley & Sons, Ltd

How to cite this article:

*WIREs Energy Environ* 2016. doi: 10.1002/wene.209

## INTRODUCTION

According to International Energy Agency estimates,<sup>1</sup> some 1.3 billion people live without electricity access. It is well known that access to energy and electricity is strongly linked to human well-being. Energy poverty is not only common in rural areas, but also in the urbanizing parts of the developing countries.<sup>2,3</sup> Bringing energy to the populations in the developing world should therefore be of high priority on the political agenda. Most of the developing countries across Africa, Latin America, and Asia are geographically situated in sunny regions, which makes solar energy a potential domestic energy source in these

countries. For example, the renewable and solar energy potential in Africa or India is substantial.<sup>1,4</sup> Combining this potential with rapid decreases in the cost of solar photovoltaics (PVs) has made decentralized energy systems, such as community microgrids, a feasible strategy of rural electrification.<sup>5</sup>

Solar energy and small-scale grids have been applied in many developing countries for rural electrification.<sup>6</sup> A new generation of PV systems for small-scale local use based on micro- or picogrids addressing the needs of the poorest people is emerging.<sup>7</sup> Such systems are increasingly developed and deployed in India,<sup>8</sup> where 68% of the population still live in rural areas and often lack electricity services. This focus article reports results from a field project with different techno-economic approaches to the commercial deployment of solar microgrids. The uniqueness of our project is in investigating three different technology options each with a different business model accompanied by a careful data collection and data analysis exercise. The findings are relevant to both improving the technology and increasing the uptake of PV-microgrids.

\*Correspondence to: ju2178@columbia.edu

<sup>1</sup>School of International and Public Affairs, Columbia University, New York, NY, USA

<sup>2</sup>Department of Applied Physics, School of Science, Aalto University, Espoo, Finland

<sup>3</sup>Department of Political Science, Columbia University, New York, NY, USA

Conflict of interest: The authors have declared no conflicts of interest for this article.

The next section presents an overview and evaluation of distributed energy for rural electrification. We then present our case study methodology and summarize the results. The conclusion of the article summarizes the implications of the research for academics and practitioners.

## DISTRIBUTED ENERGY FOR RURAL ELECTRIFICATION

Distributed energy resources (DER) encompass a wide variety of energy technologies, notably locally generated renewable sources such as solar power. DER applications range from simple, individual devices like solar PV lanterns, operating at less than 10 W, to the electrification of entire villages in the kW- and MW-scale. In the context of a village serving several households, a complete DER-based energy system would typically include the power production unit (e.g., PVs), power distribution grid, battery pack, power management or control unit, and possibly a back-up fuel-based generator.

Compared to distributed power generation in developed countries, rural DER applications often differ not only in size, but also in the electric grid structure. Rural regions seldom have an established power infrastructure.<sup>8</sup> Rural micro- or picogrids typically serve a limited number of load units, possess short grid cables, and feature a DC voltage system.<sup>9</sup> Urban microgrids and large rural systems must serve higher load demands with more user endpoints, necessitating higher voltage AC delivery and more sophisticated power electronics.<sup>10</sup>

In this study, we test a small-scale, PVs-and-battery setup DER, with or without a DC-microgrid, appropriate for the power demands of energy-poor households. Challenges faced with this type of system are both technical and economic in nature, typically regarding system performance, reliability, affordability, and financing which we address in further detail. Several studies have earlier touched upon these issues. For example, one study indicated that the type of reimbursement of solar power in villages may significantly affect the utilization rate of these systems due to under-development of local banking.<sup>11</sup> Ulstrup et al.<sup>12</sup> find that sociotechnical factors may create challenges, especially in contexts where learning effects drive demand growth overwhelming system capacity. DER system quality may also contribute to uneven performance.<sup>13</sup> Needless to say, the gap between people's ability to pay and cost of electrification and how to bridge it is a crucial issue for the adoption of small PV-grids.<sup>14</sup> However, Casillas and

Kammen<sup>15</sup> demonstrated that significant cost savings can be realized through combining energy metering, efficient lighting, and renewable electricity compared to traditional diesel generators.

## CASE STUDY: DATA AND METHODOLOGY

The field project was implemented in the Unnao district of Uttar Pradesh, India from July 2014 through May 2015. The 2011 Census of India shows that only 59% of Unnao's 1689 villages possessed any electricity access.<sup>16</sup> A survey conducted in 2014 further shows that in villages surrounding our study site only 44% of households had electricity access.<sup>17</sup> The same survey reveals that more than 95% of households in the area used at least some kerosene for lighting on a monthly basis, with a mean kerosene expenditure of 100 and a mean total expenditure of 5880 rupees (Rs.).<sup>a</sup> These numbers provide evidence that the study area is energy-poor and an appropriate setting to examine the effects of solar microgrid access and financing.

The primary project partners were the Indian social enterprise, Boond Engineering & Development, and the survey research company, MORSEL India. Boond has a branch in the district capital, Unnao City, which facilitated project implementation and reduced the likelihood of issues arising from lack of familiarity with local needs or context. Boond installed and operated the solar microgrids while MORSEL India carried out all enumeration activities. A single enumerator, trained by a member of the research team, conducted all baseline and weekly participant surveys, with a second enumerator contributing to the collection of endline surveys, to maximize consistency in data collection methods. All interactions with study participants were conducted in Hindi, the local language. The installations were inspected on a weekly basis by the enumerator to ensure that they were operating and there were no technical problems. If a problem was detected, both Boond and the research team were informed, and then corrected by the local Boond office.

For the study households, participation in the project was voluntary and not compensated. System capacity limited the number of households to a maximum of 25 at any given time. We deemed this number sufficiently large for making robust inferences about consumer behavior, satisfaction, and technical problems.

## Technologies and Business Models

In consultation with Boond, we focused our evaluation on three technological options, each with a different payment arrangement.<sup>b</sup> The first was a centralized charging station for batteries which was installed in the Aira-Bhadiyar habitation. In this setting, participating households were provided with a battery sufficient to power one LED and a mobile charger. Subscribers would drop off their battery at a Boond energy center in the village for recharging which would be completed in a few hours, depending on the battery's charge level. The central charging station consists of one 0.1 kWp solar panel which can recharge 15 solid lead-acid batteries of 0.9 kWh capacity at a time, with a typical bus voltage of 12 V. If operated by a single household, a fully charged battery system would provide about 8–10 h of lighting and mobile charging. Under this power-sharing scheme, individuals were provided enough energy to power the light and mobile charger for about three days under typical lighting and mobile phone recharging use patterns. Subscribers under this arrangement chose between paying a monthly Rs 50 service fee or Rs 5 for each battery recharge, and 23 households subscribed to this service.

The second option, installed in Sathara village, was a conventional, 'postpaid' solar microgrid through which each participating household received a wired connection to the central unit which consisted of a 0.8-kWp PV module, a 5.8-kWh battery bank, and a charge control unit. Under this model, subscribers paid a monthly fee of Rs 150 for two LED lights and a mobile phone charger. The 25 subscribers were able to power their lights and charger at any time, so long as the central battery was not discharged. The households had energy meters to connect their individual loads to the system, but also to inform them of how much electricity they have consumed. A higher bus voltage of 96 V was selected to minimize grid losses.

The third option was a newly developed, 'prepaid' solar microgrid installed in Para village. In this system, people would purchase electricity credits at 10 Rs. per 0.1 kWh from a local entrepreneur operating the system. The electricity credit could then be used to power two LED lights and a mobile charger. Aside from the different pricing regime, this system's technical design was similar to Sathara's system. Over the study period, participants registered 281 transactions (averaging 11.2 per household) totaling 79.4 kWh of consumption. A total of 25 households subscribed to this service.

The systems are illustrated in Figure 1. The panel (a) shows the centralized charging station in Aira-Bhadiyar and the panel (b) shows the microgrids in Para (prepaid) and Sathara (postpaid). For

each of the systems, the goal was to recover part of the investment through subscriber payments. In the centralized charging station (Aira-Bhadiyar), a total of USD 1417 was invested and the goal was to recover USD 354 (25%) from the community within one year. In the postpaid system (Sathara), the investment was USD 3359 and the goal was to recover USD 1067 (32%) within one year. In the prepaid system (Para), the investment was USD 3547 and the goal was to recover USD 1454 (41%) within one year. As these goals show, Boond assumed that increased technical sophistication would allow greater sales and, thus, less dependence on subsidies.

Figure 2, in turn, shows the breakdown of costs across system components. As the figure shows, the breakdown of costs is largely similar across the systems. The only difference is that the cost of the solar panel is a much smaller component of the total cost in the centralized charging station than in the two microgrid systems.

## Data Collection

Baseline surveys were conducted prior to launching the microgrid service. Subscribers were selected from market awareness camps conducted by Boond in the selected, unelectrified villages. Households were monitored for a period of 10 months during which the enumerator conducted weekly surveys with all participants. In the beginning of the project, we interviewed all households that chose to subscribe to the Boond service, along with a random sample of approximately 60 nonsubscribers from the same village. The systems were installed only after the baseline survey, and data collection began as soon as the installation was finished. All subscribing households were interviewed once a week for 5 min about their customer experience and satisfaction with the system. At the end of the project, the households were interviewed once more. Both the baseline and the endline surveys lasted 20–30 min. In total, seven subscribers canceled their participation prior to the project's completion. In four of these instances, replacement households were immediately found.<sup>c</sup> In an additional two instances, one in Para and one in Sathara, subscribers left because they had purchased private solar home systems.

While the baseline survey focused on standard socioeconomic covariates and prior energy use patterns, the weekly surveys emphasized customer experience and system performance. From the weekly survey, we used the following indicators to measure the performance of the systems:

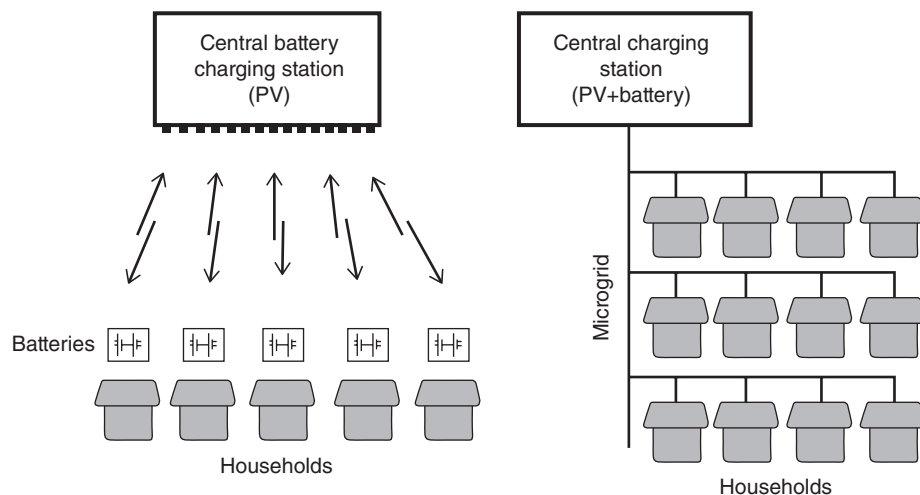

**FIGURE 1** | Graphical illustration of the systems. The system on the left was installed in Aira-Bhadiyar and the system on the right in Para (prepaid) and Sathara (postpaid).

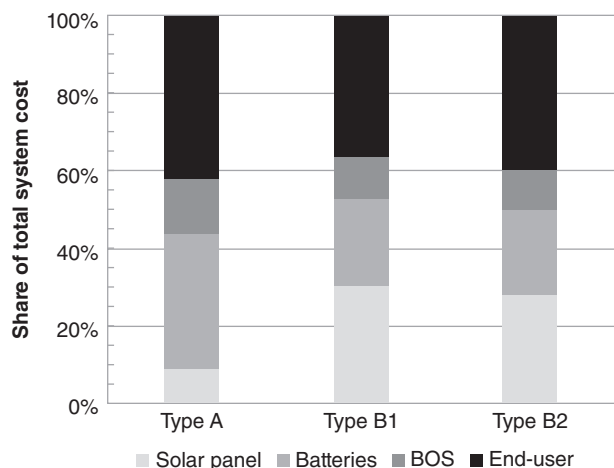

**FIGURE 2** | All-inclusive system cost to deliver energy services for the households, relative to the total (100%). The system cost is divided into four subcategories: solar panel = cost of the PV modules; batteries = cost of the battery system; BOS = balance of system components cost, such as cables and connectors, and installation work needed to make the system operational; end-user = equipment cost in the households, including appliances and lighting units. Type A is the centralized charging station in Aira-Bhadiyar; type B1 the postpaid system in Sathara; type B2 the prepaid system in Para.

- How often did the household face difficulties because of technical problems, on a 1–5 scale?
- How many problems with solar lights and the mobile charger did the household report within the past week?
- How satisfied was the household with the electricity service, on a 1–5 scale?
- How much did the household feel that capacity constraints prevented it from using enough electricity within the past week, on a 1–5 scale?

These key outcomes were measured in the weekly surveys which enabled us to monitor satisfaction and the frequency of problems as the program progressed. We report the average outcomes across the three villages below.

Table 1 compares subscribers and nonsubscribers in the three villages according to their baseline survey responses. Interestingly, across most of the characteristics the differences between subscribers and nonsubscribers, as well as across villages, are limited. Subscribers tend to be somewhat younger and have as a result resided in the location for fewer years. They also tend to be less engaged in wage labor and own somewhat more land. Overall, though, the most striking feature of the table is the similarity of subscribers and nonsubscribers, as well as households between the villages. These similarities are conducive to comparing the performance of the three systems across the villages.

In Para village, we also recorded purchases of electricity credit directly from the energy meters of the prepaid system. In Aira-Bhadiyar, we kept track of battery recharges at the energy center. These technical data sources supplement the primary weekly surveys in our evaluation of system performance.

## FINDINGS

We present the findings in three parts. First, we evaluate system technical performance, as perceived by the surveyed households. Second, we discuss sales and profitability. Finally, we discuss the customer experience in a more general sense.

**TABLE 1** | Balance Table for the Three Villages under Study

	Aira-Bhadiyar			Para			Sathara		
	Subscriber	Nonsubscriber	<i>P</i>	Subscriber	Nonsubscriber	<i>P</i>	Subscriber	Nonsubscriber	<i>P</i>
Married	0.91 (0.06)	0.92 (0.03)	0.880	0.96 (0.04)	0.91 (0.04)	0.462	0.92 (0.06)	0.97 (0.02)	0.342
Age	38.09 (2.94)	43.42 (1.67)	0.110	36.60 (1.87)	42.33 (1.78)	0.059	37.76 (2.28)	45.97 (1.64)	0.007
Household size	5.70 (0.43)	7.57 (1.46)	0.451	5.84 (0.49)	5.60 (0.28)	0.655	4.92 (0.37)	6.37 (0.34)	0.016
Years living in location	34.61 (3.25)	38.45 (2.16)	0.354	34.64 (2.17)	36.67 (2.29)	0.591	36.20 (2.42)	43.94 (1.86)	0.022
Reads Hindi	0.78 (0.09)	0.86 (0.04)	0.380	0.68 (0.10)	0.60 (0.07)	0.514	0.76 (0.09)	0.70 (0.06)	0.541
Years schooling	6.83 (1.00)	6.05 (0.52)	0.462	5.16 (0.89)	4.21 (0.55)	0.354	5.40 (0.75)	5.10 (0.51)	0.747
1 (wage labor last week)	0.09 (0.06)	0.23 (0.05)	0.136	0.16 (0.08)	0.53 (0.07)	0.001	0.04 (0.04)	0.26 (0.06)	0.020
Land holdings (acres)	0.63 (0.24)	0.09 (0.04)	0.001	1.58 (0.67)	0.44 (0.09)	0.014	2.16 (0.54)	1.63 (0.21)	0.263
1 (own tractor)	0.17 (0.08)	0.08 (0.03)	0.191	0.08 (0.06)	0.02 (0.02)	0.164	0.20 (0.08)	0.03 (0.02)	0.009
1 (own mobile phone)	0.87 (0.07)	0.83 (0.05)	0.666	0.80 (0.08)	0.66 (0.06)	0.191	0.84 (0.08)	0.82 (0.05)	0.848
# Televisions	0.26 (0.09)	0.22 (0.06)	0.678	0.20 (0.10)	0.12 (0.04)	0.395	0.32 (0.13)	0.29 (0.07)	0.822
1 (outstanding loans)	0.30 (0.10)	0.46 (0.06)	0.194	0.04 (0.04)	0.07 (0.03)	0.616	0.28 (0.09)	0.37 (0.06)	0.425
Solar technology knowledge (1 = extremely familiar)	3.87 (0.23)	2.85 (0.18)	0.003	3.32 (0.19)	3.64 (0.15)	0.218	3.40 (0.22)	3.39 (0.11)	0.954
Observations	23	65		25	58		25	62	

For each village we show the summary statistics of subscribers and nonsubscribers, as well as the *P*-value from a test of difference in means.

## Technical Performance of Systems

Figure 3 provides a graphical illustration of the problems perceived by the households in the three different villages. Panel (a) shows overall perceptions of technical difficulties, with higher values indicating more difficulties. Panels (a) and (b) count reports of problems with the two primary uses of the system, i.e., the solar lights and the mobile charger. Overall, across all three villages, panel (a) shows that the typical perception is that there were 1–2 problems of any kind in the typical week (value 2 on the *y*-axis).

However, the types of problems vary greatly across the villages. In Aira-Bhadiyar, where Boond

installed the centralized charging station, people report 0.3 problems per week with the lights, while in Para and Sathara, where microgrids were installed, the typical number is approximately 0.1 problems per week. This suggests that the solar microgrids were a significant improvement over the centralized charging approach in lighting service delivery. However, the opposite holds for mobile chargers. While Aira-Bhadiyar households typically reported about 0.2 problem per week, people in Para reported more than 0.3 and Sathara participants more than 0.4 problems. Here, the difference between the prepaid (Para) and postpaid (Sathara) system is also notable.

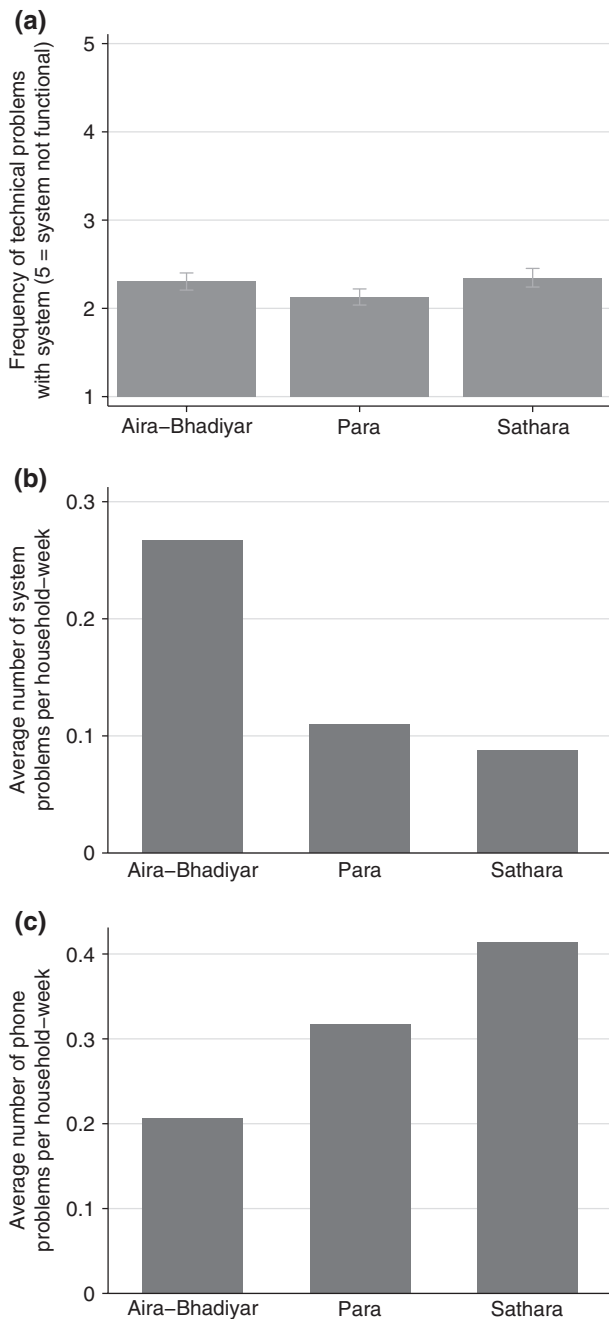

**FIGURE 3** | Technical problems reported by the households across the three villages. The responses were collected in weekly surveys over the implementation of the project: (a) perceived technical problems; (b) solar lighting problems; and (c) mobile phone problems.

Based on the reported problems in Sathara, where people could use electricity at any time, the mobile charging equipment appears to have depreciated in use faster than in Para.

However, households in all three villages reported few problems with making payments for

electricity. In all villages, the average response to a question about the ease of making payments was between 4 and 5, with 4 denoting ‘easy’ and 5 ‘very easy.’ The microgrids in Para and Sathara did somewhat better than the centralized charging station in Aira-Bhadiyar, but in none of the villages did the processing of payments present a serious obstacle to electricity delivery.

A detailed energy monitoring of the studied systems was outside the scope and budget of this project. To verify the technical performance of the systems in a more objective fashion, we focused on the battery which is the most vulnerable component in a remote solar power system. Voltage is a good performance indicator for a battery, correlating with its state of charge; a low voltage indicates low capacity and *vice versa*. In Aira-Bhadiyar, where each household had a separate battery, we verified the technical performance of the system by measuring the voltage of the batteries before and after charging. All batteries operated without problems and met the expected performance during the study. The average initial voltage of the battery at the start of the charging was 5.8 V and the final value 6.4 V with a typical 7 h charging time which demonstrates acceptable performance.

Customer reports of system and component technical problems across the three sites suggest no clear winner with unambiguously superior performance. The current systems reflect a trade-off between system and mobile charging problems that might best be solved by equipping the Sathara system with more reliable wiring and electricity outlets.

## Customer Experience

The main results on customer experience are shown in Figure 4. In panel (a), we examine overall satisfaction; in panel (b), we report average satisfaction by month calculated by survey responses from weeks in each calendar month. As the figure shows, variation across the villages was considerable. In panel (a), respondents in Aira-Bhadiyar and Sathara fell somewhere between a somewhat satisfied (4) and neutral (3) position. In Para, where the prepaid microgrid was installed, however, the average response was very close to somewhat satisfied. The combination of a low number of technical problems and the flexibility afforded by the prepaid system in determining one’s own consumption appear to have given Para an advantage over the other villages.

Equally important, however, is the decreasing satisfaction over time. As panel (b) of the figure

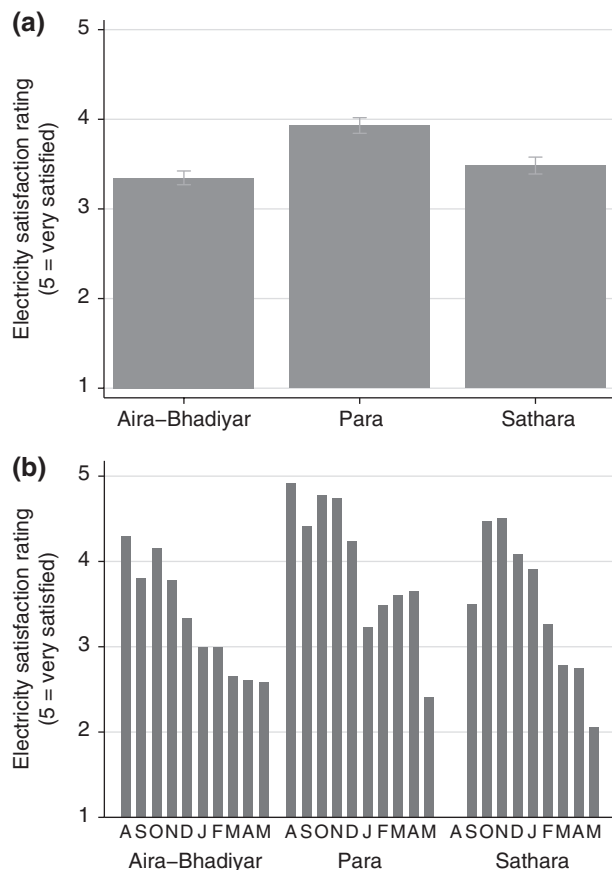

**FIGURE 4 |** Household satisfaction with Boond's electricity service. The responses were collected in weekly surveys over the implementation of the project: average satisfaction levels among customers by (a) village and (b) village and month. In panel (b), the x-axis denotes months from August 2014 to May 2015.

shows, satisfaction levels decreased in all villages over time. Based on the data and our interviews with Boond and the villagers, it appears that the increase in technical problems has over time reduced satisfaction levels among villagers. In fact, the differences across the villages appear to be driven by the early months. In May, subscribers in all households reported being between a neutral (3) and somewhat dissatisfied (2) position. The effect cannot be attributed to seasonal variation either, as in May, before the monsoon season begins in North India in June, abundant sunshine ensures that electricity is more readily available than in other seasons.<sup>d</sup>

Figure 5 shows the same results for weekly responses to stated interest in using more electricity if it were made available. Again, panel (a) shows the average results and panel (b) shows variation over time. On average, households reported being either neutral (3) or somewhat interested (4) in using more than is available, with respondents in Para and

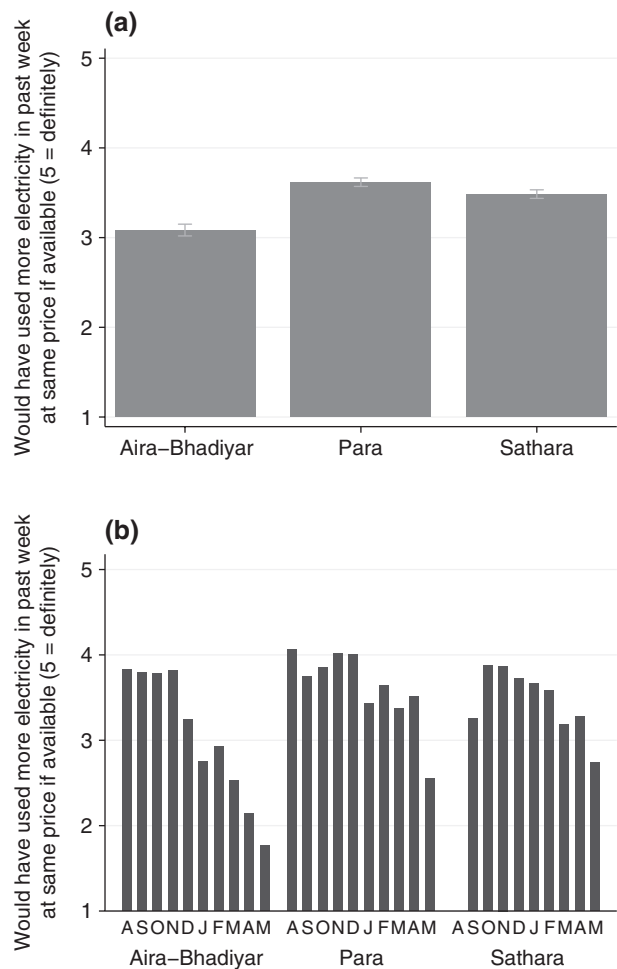

**FIGURE 5 |** Household reports of wanting to use more electricity than was available. The responses were collected in weekly surveys over the implementation of the project: average interest in using more electricity among customers by (a) village and (b) village and month. In panel (b), the x-axis denotes months from August to May, from left to right.

Sathara reporting more interest. This observation is initially surprising because the service in Aira-Bhadiyar provided only one light, but the convenience of a direct household connection through a solar microgrid could explain why the Para and Sathara users were interested in using more electricity.

Again, though, it is significant that interest in additional use of electricity went down over time. While the average subscriber reported being interested in using somewhat more electricity (4) during the first four or so months across the villages, interest declined significantly over time. By May, in Aira-Bhadiyar the average villager was somewhere between somewhat unlikely (2) and not at all (1).

To gain greater insight into how exactly households used the energy services, we included open-ended questions in our endline survey to inquire about specific ways they believe program involvement affected them, how they might use additional access, and how they would change the way the program operates. Additionally, we asked nonparticipants their key reasons for not enrolling in the program, to which financial constraints, existing ownership of a solar home system, lack of information about the program/system, distance from the grid, and inadequate need for lighting all ranked among the most cited.

As for the households which did participate in the program, a subset specified their lighting access as helping with cooking, studying, illumination at a private shop, at their temple, and for security. When responding to a question regarding how the availability of additional power would be used, most respondents stated that operating fans and televisions were their foremost priorities, with several specifying lighting applications for study, business, cooking, and socializing as being very important. As to how they would modify the system based on their experience prior to the endline, most of the responses centered on increasing battery capacity, total available electricity, and improving overall system reliability.

In brief, the decay in customer satisfaction over time is troubling inasmuch as system problems were not immediately alleviated and expectations of the system cemented. However, it must also be emphasized that customers prior to participating in the study possessed no electricity access. One potential interpretation of the results is of individuals adopting the new functionality and it becoming the norm. Any new technical complaint might then register as a larger, negative effect of satisfaction because of higher expectations later in the program. Regarding whether customers would use more electricity if available, Figure 5 suggests that a feature common to systems covering Para and Sathara makes their customers more likely to scale-up their demand. Given the relatively high, lump-sum payment method governing Aira-Bhadiyar transactions, the decline over time may be attributable to customers interpreting this question as doubling electricity access since their financing method does not allow for marginal increases in the way that a prepaid credit-based system does.

## Sales and Profitability

Assuming that operating and management costs are equal across the systems, the profitability of the three

systems can be computed simply by contrasting their capital costs with sales of electricity. In Aira-Bhadiyar, households could choose between Rs 50 per month and Rs 5 per charge. With a monthly expenditure of approximately Rs 50 multiplied by the number of customers, 23, monthly revenue is approximately Rs 1150. Assuming that this revenue would continue to flow in over time, the system would pay for its capital cost, USD 1417, in approximately 81 months. This is quite a long payback period and ignores the operating and maintenance costs.

In Sathara, households paid Rs 150 per month for access to the solar lights and mobile charging. With 25 subscribers, this amounts to a monthly income of Rs 3750. Given a capital cost of USD 3359, the system would pay for itself in approximately 59 months—a clear improvement over Aira-Bhadiyar. In Para, payments were based on prepayments for actual electricity consumption, and total household electricity purchases amounted to Rs 7940 over the experiment's duration of 10 months. The average monthly revenue, then, is only Rs 794. Given a capital cost of USD 3547, the system would pay for itself over a period of 295 months—by far the worst economic performance of the three systems.

Comparing these numbers, we see that the new innovation in Para indeed allowed households to dramatically reduce their electricity consumption. In doing so, however, the system also makes the solar business financially unviable.

## CONCLUSION

The results above shed new light on the techno-economic feasibility of different off-grid solar systems. By comparing three different systems—one centralized charging station and two microgrids—we found that there is a trade-off between economic performance and customer satisfaction. Overall, the customers found the flexible prepaid system, which allows customers to choose their own expenditure levels, the best solution. However, the system was also the least profitable because customers consumed very small amounts of power. Of the three systems, the postpaid microgrid system struck a balance between profitability and customer satisfaction, but the system did suffer from a higher number of technical problems related to mobile phone charging.

These results suggest that the prepaid system requires modifications for commercial applications. One approach could be to combine a fixed monthly fee with a somewhat higher consumption fee.



However, the capital cost of the system could be reduced with smaller solar panels and batteries. A third approach would be to offer better services to the households, such as a fan and a television. If these services were attractive enough, the consumption of power could increase sufficiently to increase the profitability of the system.

## NOTES

<sup>a</sup> On May 1, 2014, the INR:USD exchange rate was approximately 60:1.

<sup>b</sup> Under all of these systems, payment in cash was collected from subscribers at the nearest Boond energy center.

<sup>c</sup> At least two of these households cited dissatisfaction with the battery as the primary reason for dropping out.

<sup>d</sup> According to direct normal irradiance data collected by the National Renewable Energy Laboratory and India's Ministry of New and Renewable Energy, average irradiance for May at 26.55°N, 80.45°E exceeds average values for all subsequent months in the calendar year. See <http://mnre.gov.in/sec/solar-assmnt.htm> for more details.

## ACKNOWLEDGMENTS

We thank Fortum Corporation and TEKES for funding this project. We are grateful to Boond Engineering and Development for implementation and to MORSEL India for data collection. Imran Asghar gave useful comments on a previous draft.

## REFERENCES

1. IEA. *World Energy Outlook*. Paris: International Energy Agency; 2014.
2. Aklin M, Patrick B, Harish SP, Urpelainen J. Quantifying slum electrification in India and explaining local variation. *Energy* 2015, 80:203–212.
3. Singh R, Wang X, Mendoza JC, Ackom EK. Electricity (in)accessibility to the urban poor in developing countries. *Wiley Interdiscip Rev Energy Environ* 2015, 4:339–353.
4. IRENA. *REmap 2030: A Renewable Energy Roadmap*. Abu Dhabi: International Renewable Energy Agency; 2014.
5. Lopes JAP, Madureira AG, Moreira CCLM. A view of microgrids. *Wiley Interdiscip Rev Energy Environ* 2013, 2:86–103.
6. Nygaard I, Dafrallah T. Utility led rural electrification in Morocco: combining grid extension, mini-grids, and solar home systems. *Wiley Interdiscip Rev Energy Environ* 2015. doi:10.1002/wene.165.
7. Chaurey A, Kandpal TC. Assessment and evaluation of PV based decentralized rural electrification: an overview. *Renew Sustain Energy Rev* 2010, 14: 2266–2278.
8. Raman P, Murali J, Sakthivadivel D, Vigneswaran VS. Opportunities and challenges in setting up solar photo voltaic based micro grids for electrification in rural areas of India. *Renew Sustain Energy Rev* 2012, 16:3320–3325.
9. Chaurey A, Kandpal TC. A techno-economic comparison of rural electrification based on solar home systems and PV microgrids. *Energy Policy* 2010, 38:3118–3129.
10. Lidula NWA, Rajapakse AD. Microgrids research: a review of experimental microgrids and test systems. *Renew Sustain Energy Rev* 2011, 15:186–202.
11. Soto D, Adkins E, Basinger M, Menon R, Rodriguez-Sanchez S, Owczarek N, Willig I, Modi V. A prepaid architecture for solar electricity delivery in rural areas. In: *Proceedings of the Fifth International Conference on Information and Communication Technologies and Development*, Atlanta, GA, USA; 2012, 130–138.
12. Ulsrud K, Winther T, Palit D, Rohrer H, Sandgren J. The solar transitions research on solar mini-grids in India: learning from local cases of innovative socio-technical systems. *Energy Sustain Dev* 2011, 15:293–303.
13. Millinger M, Mårilind T, Ahlgren EO. Evaluation of Indian rural solar electrification: a case study in Chhattisgarh. *Energy Sustain Dev* 2012, 16:486–492.
14. Mainali B, Silveira S. Financing off-grid rural electrification: country case Nepal. *Energy* 2011, 36: 2194–2201.
15. Casillas CE, Kammen DM. The delivery of low-cost, low-carbon rural energy services. *Energy Policy* 2011, 39:4520–4528.
16. Government of India. 2011 census report, houselisting and housing census data highlights, 2011. Available at: [http://www.censusindia.gov.in/2011census/hlo/hlo\\_highlights.html](http://www.censusindia.gov.in/2011census/hlo/hlo_highlights.html). (Accessed November 30, 2015).
17. Urpelainen J, Yoon S. Solar home systems for rural India: survey evidence on awareness and willingness to pay from Uttar Pradesh. *Energy Sustain Dev* 2015, 24:70–78.